

PROOFF

progressive office

#002

PROOFF #002 WorkSofa
by Studio Makkink & Bey















#002

PROOFF #002 WorkSofa
by Studio Makkink & Bey



AN INSPIRING PLACE
BUILT FOR COMMUNICATION.
SITTING. STANDING.
LOUNGING. CLOSE-UP.
SIDE BY SIDE
OR ACROSS.

Honouring needs

The idea for the WorkSofa grew out of our commitment to stimulate ‘genuine’ communication. We believe that by sitting naturally we can influence people’s approach to one another. After intensive research into the activity of sitting and the nature of maximizing social activity, Studio Makkink & Bey have come across many different possibilities for creating a new furniture piece.

As a result of these, the idea of modularity and flexibility became the primary focus in creating the WorkSofa — essential ingredients when it comes to honouring the needs of users. In every instance the different characteristics of the WorkSofa offer many new possibilities and configurations in which stylish pieces of the puzzle allow for endless varieties of communication to occur. From informal to intimate, the modular WorkSofa has proven itself as an ideal setting for public meetings, presentations, brainstorm sessions and group work — or even a place to have a meeting with oneself. As the sofa changes, new ways of being social are revealed, depending on which height and layout suits your meeting.

Dimensions

TYPE 1

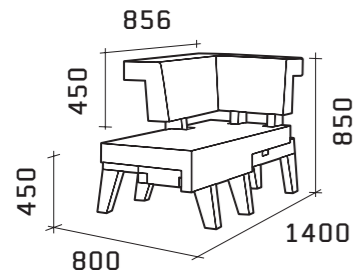

TYPE 2

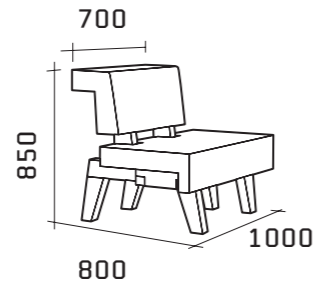

TYPE 3

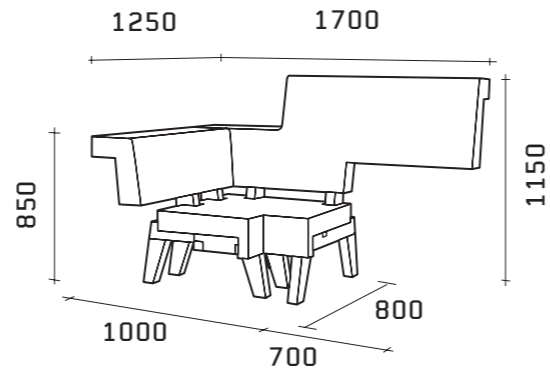

TYPE 4

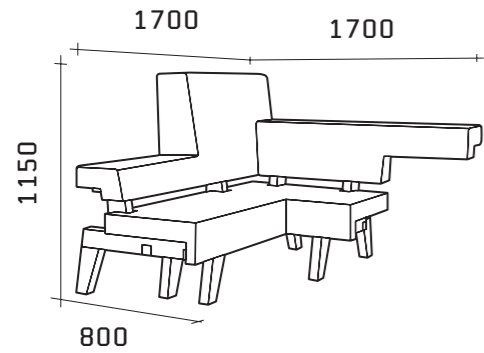

TYPE 5

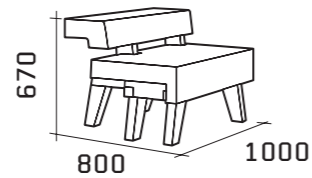

TYPE 6

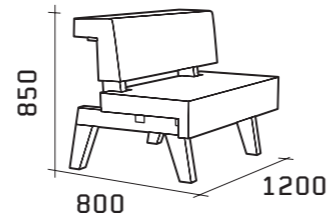

The design concept is that the back and the seat are upholstered in two different colours, preferably in a similar colour scheme. It is also possible to have the seat and back in a different colour and upholstery. With the 6 elements you can create your own space and allow for endless varieties. In each of the configurations a different character is revealed, from formal to intimate. As the sofa changes, new ways of being social are revealed depending on which height and layout suits your meeting.

Types

TYPE 1

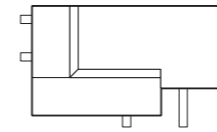

TYPE 2

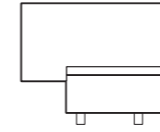

TYPE 3



TYPE 4

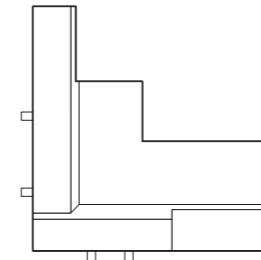

TYPE 5

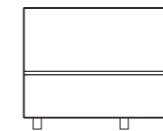

TYPE 6

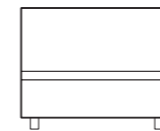

Configurations

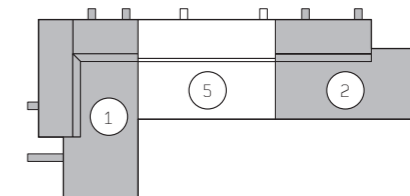
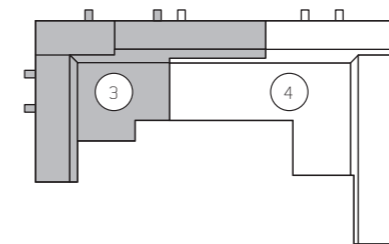
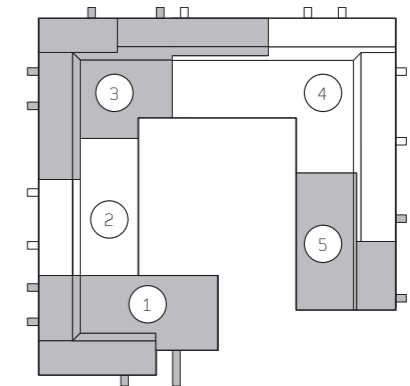
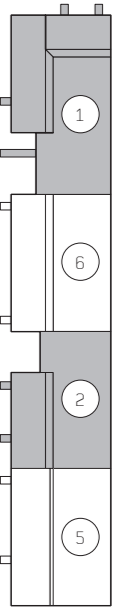
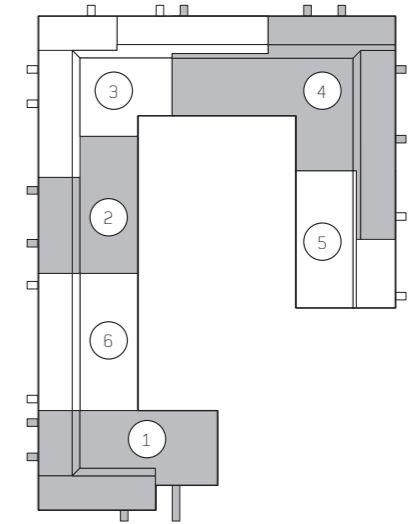



“Making connections is easy and it feels like we find solutions and creative ideas faster. What it is, I’m not sure. But it works!”



“They’re puzzle pieces which transform to your liking. It invites exploration of new ideas and stimulates your imagination. And all subconsciously.”

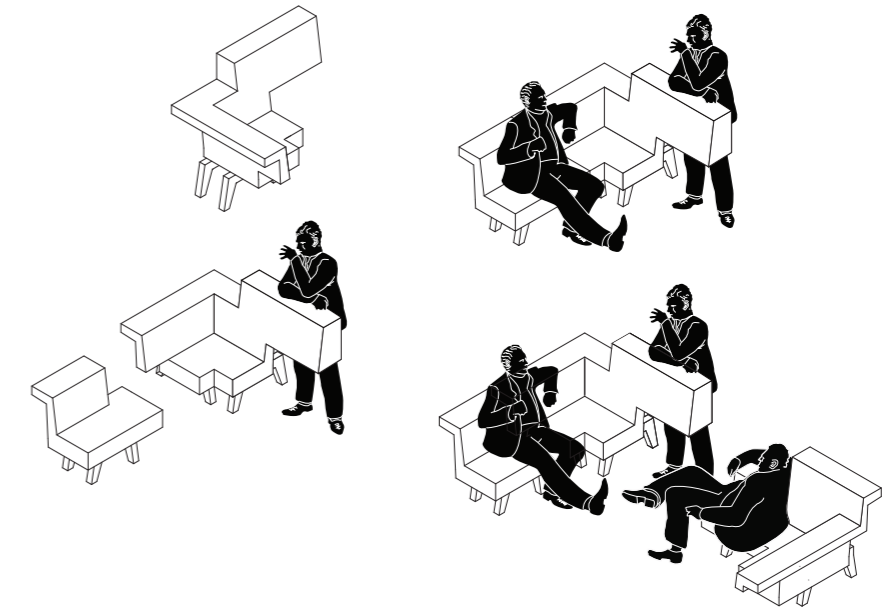

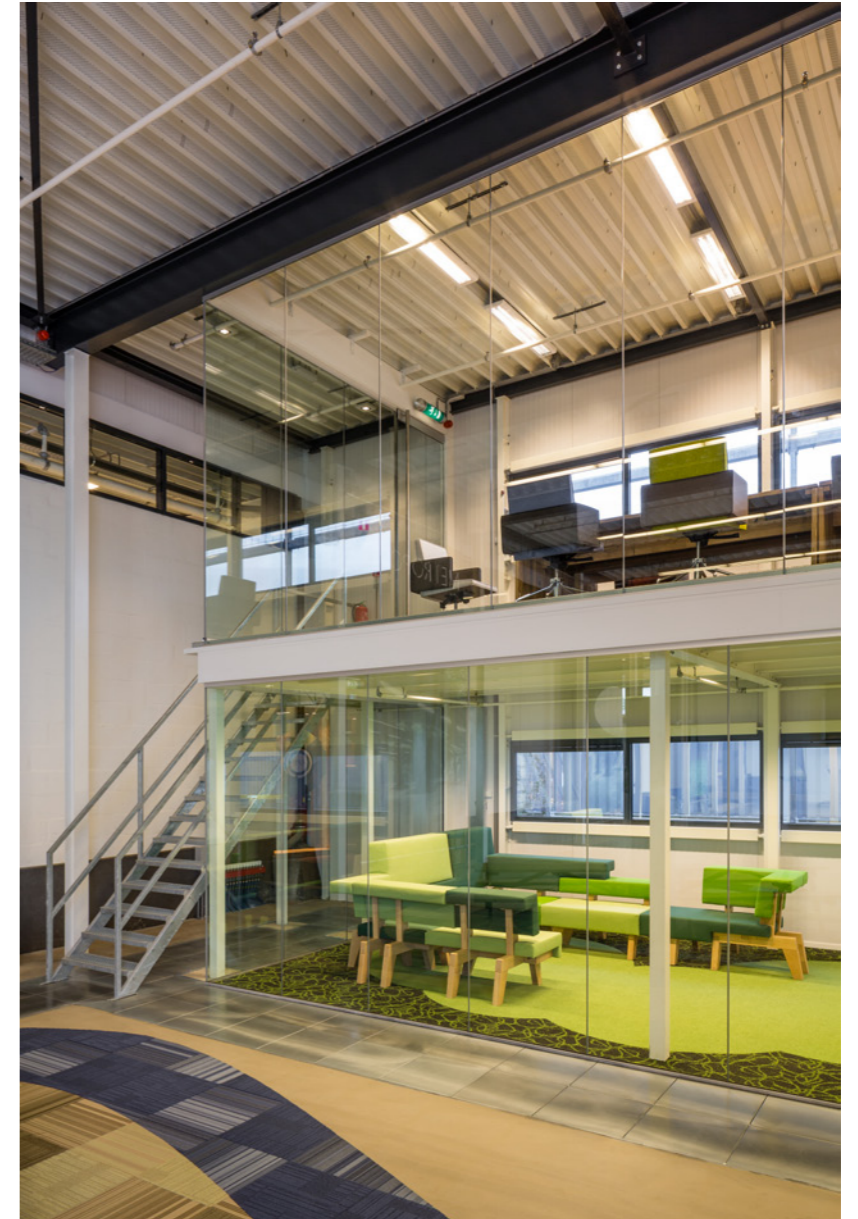

PROOFF Collection bv
p.o. box 34095
3005 GB Rotterdam
The Netherlands

+31 10 211 00 80
contact@proof.com

www.prooff.com

twitter: @prooffnl
facebook: /prooffnl