

PROOFF

progressive office

#001

PROOFF #001 EarChair
by Studio Makkink & Bey















#001

PROOFF #001 EarChair
by Studio Makkink & Bey



SHELTER FROM
THE CLAMOR.
PUBLIC TURNS
PRIVATE.

Like a room

What happens when furniture is designed with the idea that it should behave like a room? It results in a private domain which exists comfortably within a public space, a proper resting place in the middle of it all, a flexible & social meeting ground that can exist almost anywhere. For example, when a chair has been designed with a proper height and is built with a rounded aesthetic, the result is a well resolved acoustic EarChair that lets you be yourself in your own personal space. Add another to the equation and you have created a room within a room.

It is here, in open public space, where you can have a personal conversation, make a telephone call or listen privately to what you choose. The integrated table in the armrest of the EarChair also offers a personalized place for you to simply enjoy your coffee, write your notes, or work on your laptop. No matter how many chairs or how big the room actually is, the EarChair's unique variations of colour and fabric choice allow for every room to take on its own personal character.

Dimensions

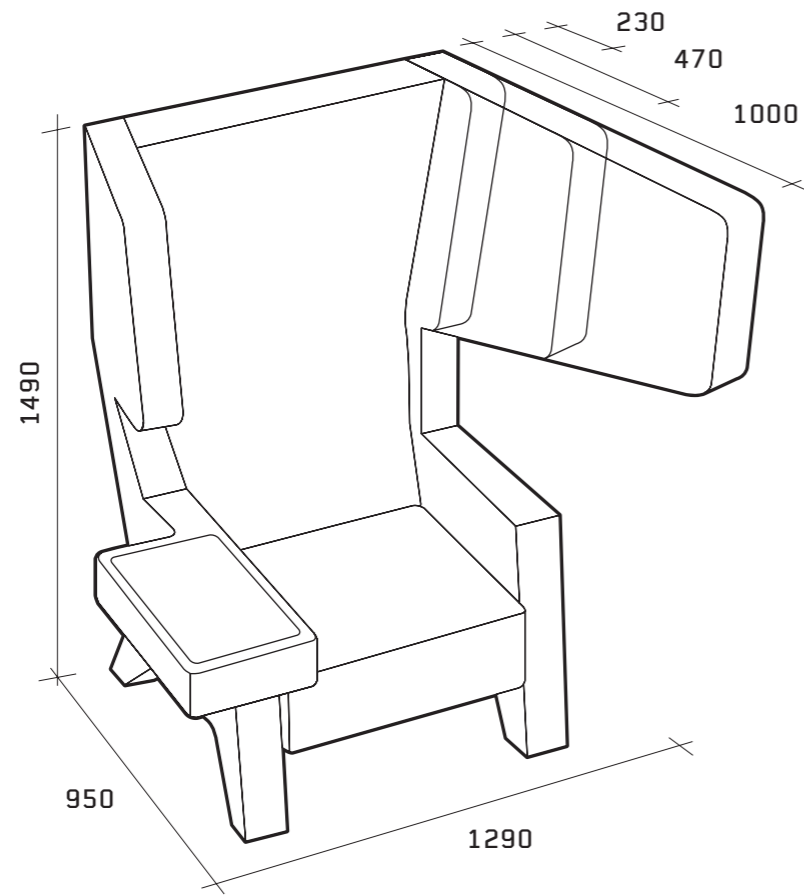

The EarChair comes with 3 different 'ears': small, medium and large. We offer 10 models, depending on the dimensions of the 'ear' and position of the table armrest. The more EarChairs you add, the bigger your room within a room. You can add character to your room by selecting from different types of upholstery and/or colour for the inside and outside of the chair.

Types

TYPE 1

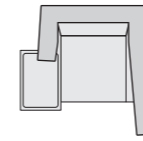

TYPE 2

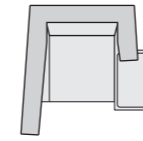

TYPE 3

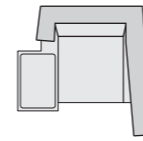

TYPE 4

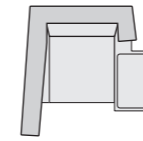

TYPE 5

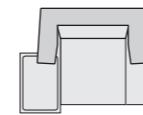

TYPE 6

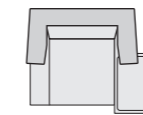

TYPE 7

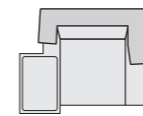

TYPE 8

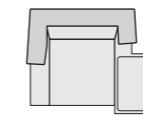

TYPE 9

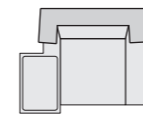

TYPE 10

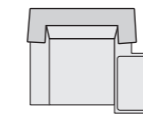

Configurations

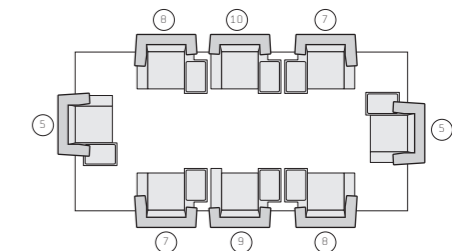
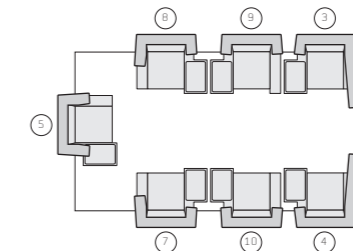
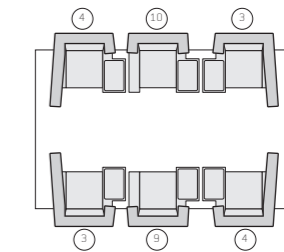
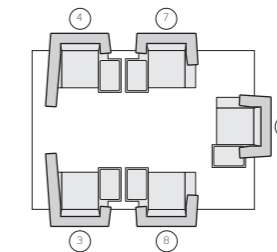
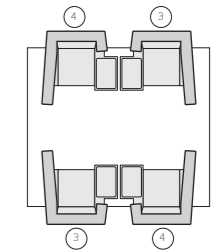
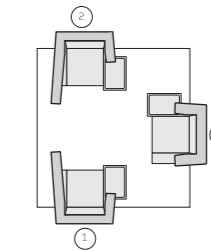
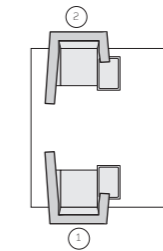



“Briefly nestled away from the bustle of the world and focused on our assignment. Inspired by the many colours and bold design. This space could easily inspire nine out of ten successful ideas!”





**“A fascinating space within a space.
An informal meeting place. One on one
or with my team. Exterior sounds are
blocked out* and seclusion is provided.”**

* Research shows that the EarChair reduces the background noise level by 13 dB.
With a reduction of 10 dB the user experiences half the background noise.



PROOFF Collection bv
p.o. box 34095
3005 GB Rotterdam
The Netherlands

+31 10 211 00 80
contact@prooff.com

www.prooff.com

twitter: @prooffnl
facebook: /prooffnl